

# TPC-1571H

## 15" XGA TFT LCD Intel® Atom™ Dual-Core D525 Touch Panel Computer



### Features

- Intel® Atom™ processor up to 1.8 GHz
- 15" XGA TFT LCD
- Compact design with die-cast Al front bezel
- Fanless cooling system
- NEMA4/IP65 compliant front panel
- PCIe and Mini PCIe expansion support
- 8 DI/O and backup SRAM support
- Supports DDR3 SDRAM
- Serial port isolation protection
- Automatic data flow control RS-485
- Gigabit Ethernet supported
- Supports Microsoft® WES7/ XP/ WES / WinCE

### Introduction

With a high quality TFT LCD display, TPC-1571H is designed with the Intel® Atom™ D525 processor as its core. The Intel® Atom™ has low power consumption and 1.8 GHz operating frequency. This system is fanless although the kernel is powerful. In addition, spindle-free storage makes the TPC-1571H a durable and reliable platform. For applications where spindle-free storage is not critical, a fast-access HDD module can be used. The rich I/O portfolio meets diverse requests.

### Specifications

#### General

- **BIOS** AMI
- **Certifications** BSMI, CCC, CE, FCC Class A, UL
- **Cooling System** Fanless design
- **Dimensions (W x H x D)** 383 x 307 x 78.5 mm (15.08" x 12.09" x 3.09")
- **Enclosure** Front bezel: Die-cast Aluminum alloy  
Back housing: ABS + PC
- **Mounting** Desktop, Wall or Panel Mount
- **OS Support** Microsoft® WES7/ XP/ WES / WinCE 5.0/6.0
- **Power Consumption** 21 W (typical)
- **Power Input** 10~29 V<sub>DC</sub>
- **Watchdog Timer** 1 ~ 255 sec (system)
- **Weight (Net)** 5.5 kg (12.13 lbs)

#### System Hardware

- **CPU** Intel® Atom™ D525 1.8 GHz with 1MB cache
- **Chipset** ICH8M
- **Memory** 4GB SO-DIMM DDR3 SDRAM
- **LAN** 10/100/1000Base-T x 2
- **Expansion Slots** Full-size PCI-E or Mini PCI-E
- **Storage** CompactFlash® slot x 1  
2.5" SATA HDD x 1 (Optional)
- **I/O** RS-232 x 2 (COM1, 2) with isolation  
RS-422/485 x 1 (COM3) with isolation and auto data flow control  
USB 2.0/1.1 x 2 (Host)  
PS/2 x 1
- **DI/DO & backup SRAM** 8 x DI/DO with isolation and backup 1MB SRAM

#### LCD Display

- **Display Type** XGA TFT LCD
- **Display Size** 15"
- **Max. Resolution** 1024 x 768
- **Max. Colors** 262 K
- **Luminance cd/m<sup>2</sup>** 350
- **Viewing Angle (H/V°)** 160/140
- **Backlight Life** 50,000 hrs
- **Contrast Ratio** 700 : 1

#### Touchscreen

- **Lifespan** 10 million touches at single point
- **Light Transmission** Above 75%
- **Resolution** Linearity
- **Type** 5-wire, analog resistive

#### Environment

- **Humidity** 10 ~ 95% RH @ 40°C, non-condensing
- **Ingress Protection** Front panel: NEMA4, IP65
- **Operating Temperature** 0 ~ 50°C (32 ~ 122°F)
- **Storage Temperature** -20 ~ 60°C (-4 ~ 140°F)
- **Vibration Protection** With HDD: 1 Grms (5 ~ 500 Hz)  
(Operating, random vibration)

## Dimensions

Unit: mm

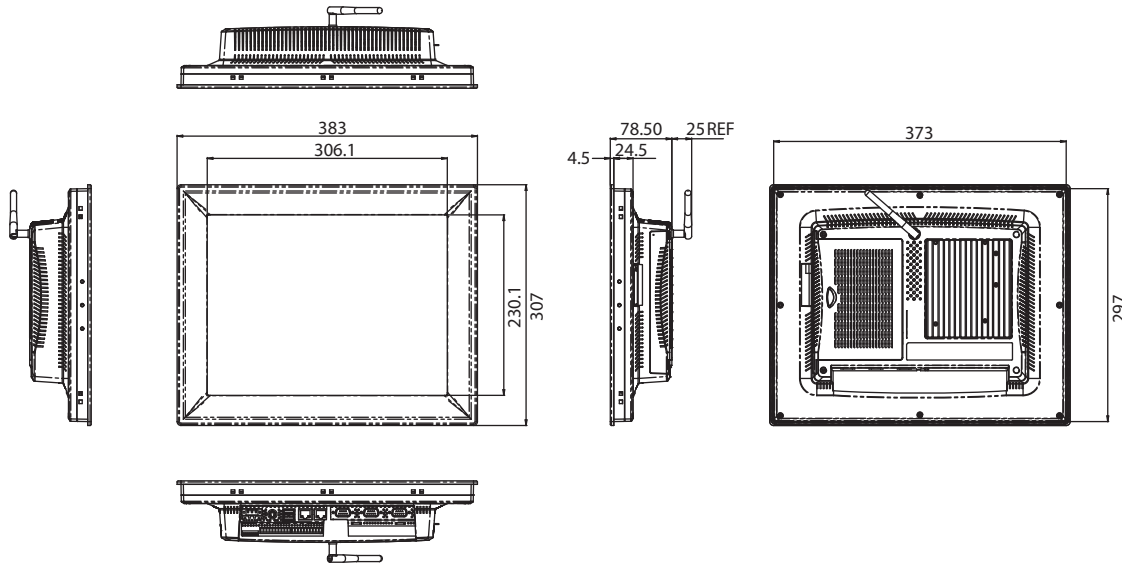

Panel Cut-out Dimensions: 374.5 x 298.5 mm

## Ordering Information

- **TPC-1571H-D3AE** 15" XGA Touch Panel PC, D525 1.8 GHz, 4GB

### Accessories

- **TPC-1000H-WMKE** TPC series wallmount kit from 10" to 17"
- **TPC-1000H-SMKE** TPC series stand kit from 10" to 17"
- **1757003463** 100-240V<sub>AC</sub> to 19V<sub>DC</sub> 90W Power Adapter
- **1700001524** Power Cord 3P UL 10A 125V 1.8M
- **1702002605** Power cable EU Plug 1.8M
- **1702031801** Power cable UK Plug 1.8M
- **1702031836** Power cable China/Australia Plug 1.8M
- **EWM-W139F01E** 802.11 b/g/n, RT5390, 1T1R, Full-size Mini-PCle
- **PWR-247-AE** 50W DC 24V/2.3A Output Power Supply
- **1750000318** EMI Antenna 2DBI 2.4GHz SMA CONN for ARK-3384
- **1750003222** 802.11b/g 5dBi Dipole Antenna
- **1750003418** Wireless Antenna AN2400-5901RS R/P SMA.M9dB

## Rear View

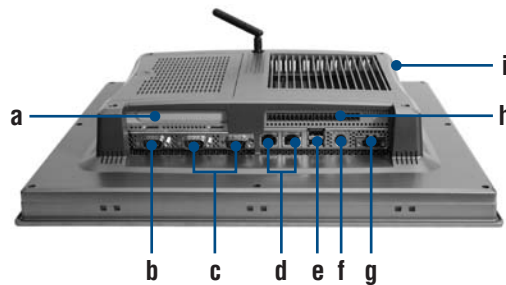

- a. PCI-E slot
- b. COM (RS-422/485)
- c. COM (RS-232)
- d. LAN (10/100/1000)
- e. USB 2.0
- f. PS/2
- g. Power Receptor
- h. DI/O ports
- i. CompactFlash

- 1 WebAccess Solution
- 2 Machine Automation
- 3 Hazardous Location Solutions
- 4 Substation Automation Gateways & RTUs
- 5 Building Automation Systems
- 6 Automation Software
- 7 Intelligent Operator Panels
- 8 Automation Panel PCs
- 9 Industrial Monitors
- 10 Industrial Ethernet Solutions
- 11 Serial Device Servers and IP Gateways
- 12 Serial Communication Cards
- 13 Embedded Automation Computers
- 14 Programmable Automation Controllers
- 15 M2M I/O Modules
- 16 Femto Controller
- 17 RS-485 I/O Modules
- 18 Ethernet I/O Modules

\* Windows XPe supports 10 languages with MUI. (English, Traditional Chinese, Simplified Chinese, French, German, Spanish, Russian, Italian, Japanese and Korean)